

INSTRUCTION MANUAL

WIRELESS DATA COLLECTOR

MODEL WDC100



QUALITY SYSTEM
ISO:9001
CERTIFIED

HYQUEST SOLUTIONS PTY LTD
PO BOX 332, LIVERPOOL B.C NSW 1871, AUSTRALIA
Phone:(Int.) 612 9601 2022 Fax: :(Int.) 612 9602 6971
Phone:(Nat.) (02) 9601 2022 Fax: :(Nat.) (02) 9602 6971
Email: sales@hyquestsolutions.com.au
Web: www.hyquestsolutions.com.au

TABLE OF CONTENTS

1. Product Overview 4

2. Installation..... 5

2.1 Planning your System..... 5

2.2 Hardware Connections (Transmitter)..... 8

2.3 Hardware Connections (Receiver) 10

2.4 Antenna Mounting..... 11

2.5 Power Supply 11

2.6 Menu Navigation 12

2.7 Configuration 13

3. Operation..... 15

3.1 Transmitter LED 15

3.2 Displaying Water Volume..... 16

4. Specification 17

4.1 Hardware Specification..... 17

Appendix A Creating the Level to Volume Formula 18

Appendix B Creating the Level to Volume Mapping..... 21

Appendix C Buoy Breather Bag Setup 24

Appendix D Sending Custom SDI-12 Commands 27

Latest Changes in Transmitter Software Rev 1.3 (7-Dec-2011)

- Should only be used with Receiver S/W Rev 1.3
- Perform Battery Charging control by switching solar to battery
- Allow the monitoring of SDI-12 data through the aM1, aM2, aM3..... aM9 commands (Previously, only the aM! Command could be used)

Latest Changes in Transmitter Software Rev 1.4 (28-Mar-2013)

- Restart the RF module if no comms in 2.5 secs - and restart entire Transmitter if no comms in 10 mins
- Added a LED flash sequence on startup
- Got the sleep working much better + goes to sleep if there is no comms - only wakes up for 7 secs every minute to check for comms again
- Saves the TipTotal accumulator if it is going to do a forced "no comms" reset
- Changed the RF freq steps to 3MHz. Range is now 904.5MHz to 925.5MHz

Latest Changes in Transmitter Software Rev 1.5 (3-Jul-2014)

- Allow Custom commands to be sent to SDI-12 devices

Latest Changes in Receiver Software Rev 1.3 (7-Dec-2011)

- Allow the configuration of SDI-12 data using the aM1, aM2, aM3..... aM9 commands
- LCD backlight now stays on for 30 secs but LCD itself stays on for 4 mins
- Allow the Volume to be calculated from the 4-20mA input or the SDI-12 input #1
- Allow an Offset to be added to SDI-12 input #1

Latest Changes in Receiver Software Rev 1.4 (27-Apr-2012)

- Changed the Volume calculation from a 4th order polynomial to a 10 point linear interpolation.
- Allow the Level to Volume configuration to be performed in a Windows App "OutpostConfig"

Latest Changes in Receiver Software Rev 1.5 (28-Mar-2013)

- If no comms at all for about 20 mins, power down the RF module for 0.4Secs, and power it up again.
- Measure and display the Rx Signal strength eg: Coms: OK-5 Range is 1 to 7
- If changing the Preset Tip count, keep sending it until message gets through (prev S/W Revisions only sent it once)
- Changed the RF freq steps to 3MHz. Range is now 904.5MHz to 925.5MHz

Latest Changes in Receiver Software Rev 1.6 (29-Jan-2014)

- Can now select which Transmitter the Receiver's digital output is driven from.
- Clock out the tips from the Receiver digital output at 2 tips per second.
- New configuration screen to enable/disable each transmitter individually – rather than using the rotary switch. The Receiver SDI-12 only responds to configured Transmitters.
- If the SDI-12 #1 Offset is not used, then meas #1 is fed through as for other measurements #2 - #9

Latest Changes in Receiver Software Rev 1.7 (3-Jul-2014)

- Allow Custom commands to be sent to SDI-12 devices on any Transmitter. This is used in conjunction with "Outpost Express" Windows application.

Latest Changes in Receiver Software Rev 1.8 (16-Jul-2014)

- Bug fix – Volume to level table now saved to non-volatile memory after updating from Windows App.

Latest Changes in Receiver Software Rev 1.9 (24-Oct-2014)

- Sets the SDI-12 Meas #1 value to 999.999 if comms to remote Transmitter is lost for 2 consecutive polls.

1. Product Overview

The HyQuest Solutions Wireless Data Collector WDC100 has been designed using surface mount technology to provide a very small, ultra low power wireless SDI-12 and 4-20mA transmitter / SDI-12 receiver network that can be used in harsh environments for extended periods.

The Wireless Data Collector's primary purpose is to periodically measure various signals at remote locations, including a 4-20mA transducer, up to 9 x SDI-12 data variables and a digital contact closure (rainfall or flow meter input) and to wirelessly transmit the data to a central location and make the data available to a data logger via an SDI-12 interface. A central receiver can collect data from up to 8 separate transmitters, each with a very low power consumption (typically 200uA while asleep) which makes it ideal for remote sites where long battery life is important. The receiver also has an LCD + keys to display the data and set configuration parameters. A new feature allows custom SDI-12 commands to be sent to any remote Transmitter SDI-12 sensor (See Appendix D)

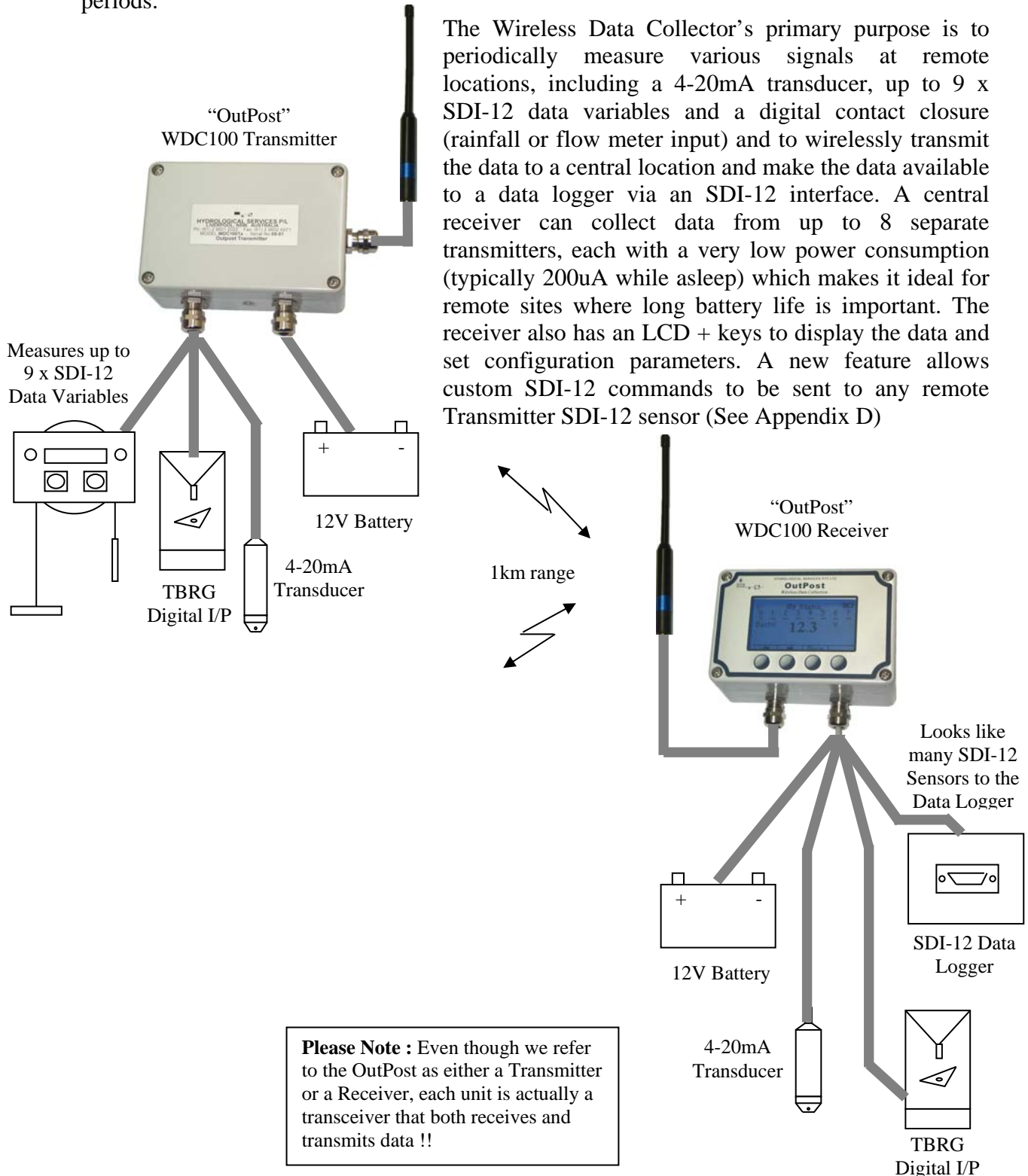

2. Installation

2.1 Planning your System

This is an important step, so you must make sure your system can achieve exactly what you require. The receiver collects data from up to 8 transmitters and has a line of sight range of up to 1km. This will be reduced by obstacles including, trees, fences, buildings, vehicles, electricity wires, hills etc. The SDI-12 data logger will be located at the receiver.

1. Select a frequency the system will operate at, and set each transmitter and the receiver to the selected frequency. If the system is in a remote location, then the frequency of operation is not important, however, if the system is located close to other equipment operating in the 915MHz band, then you may need to try different frequencies until you find one that doesn't clash. You could have several WDC100 OutPost "Systems" operating in close proximity to each other, on different frequencies. Also note that the HyQuest Solutions' Hornet, Flying Fox and Cable Fox river gauging products also use this frequency band!!! (The next chapter shows the switch used to set the transmitter and receiver frequency.)
2. The transmitters must all have a unique address between 0 and 7. (Receiver software Rev 1.5 and below requires the transmitter address to start at 0 and increase up to 7. Receiver software Rev 1.6 and above allows the transmitters address to be non-sequential.)
3. Configure the transmitters you will be polling from the "My Config" menu – in Receiver S/W Rev 1.6 and above. (If you have Receiver software Rev 1.5 and below then consider upgrading it – or use the Operators Manual Issue 1.3)
4. Decide what sensors you are going to fit to each transmitter, and what data you are going to log. **Each** transmitter can have a combination of the sensors below.

Sample : Sensors connected to **Transmitter #0** :

Input	Input Type	Used Yes/No	Description	Other Info : 4-20 Range, SDI Addr/Meas, SDI Data Pt#
	Battery Voltage	Yes	Tx #0 BV	
	4-20mA	Yes	INW PS98i	10m Range
	Volume Calc	Yes	Tank Volume 4-20	Level → Vol table
	Digital Input	No		
	SDI #1	Yes	INW PT12 Level	Addr 1, Meas 5, Data Pt 1
	SDI #2	Yes	INW PT12 WTemp	Addr 1, Meas 5, Data Pt 2
	SDI #3	Yes	INW PT12 ATemp	Addr 1, Meas 5, Data Pt 3
	SDI #4	Yes	AD375A Depth (m)	Addr 3, Data Point 1
	SDI #5	No		
	SDI #6	No		
	SDI #7	No		
	SDI #8	No		
	SDI #9	No		

5. Make sure your SDI-12 Logger can log all the variables you require! All of the data returned from Transmitter #0 will be translated to appear as data from SDI-12 address #0. All the data returned from Transmitter #1 will be translated to appear as data from SDI-12 address #1.All the data measured by the receiver itself will be translated to appear as data from SDI-12 address #8.
 The above translation is as follows :
 (Sensor connected to Tx#0 Meas#1,#2,#3 is from the example on the previous page)

Unit	Description	Sensor Connected to Transmitter :			SDI-12 Addr/Data requested by Logger	
		SDI-12 Addr/Meas	SDI-12 Data Pt		SDI-12 Addr	SDI-12 Data Pt
Tx#0	Battery Voltage	-	-	→	0M!	1
	4-20mA Water Level	-	-	→	0M!	2
	Volume Calc from 4-20mA WL	-	-	→	0M!	3
	Digital Input accumulator	-	-	→	0M!	4
	Last Measurement (hhmmss)	-	-	→	0M!	5
	SDI-12 Measurement #1 eg.	1M5!	1	→	0M!	6
	SDI-12 Measurement #2 eg.	1M5!	2	→	0M!	7
	SDI-12 Measurement #3 eg.	1M5!	3	→	0M!	8
	SDI-12 Measurement #4 eg.	3M!	1	→	0M!	9
	SDI-12 Measurement #5			→	0M1!	1
	SDI-12 Measurement #6			→	0M1!	2
	SDI-12 Measurement #7			→	0M1!	3
	SDI-12 Measurement #8			→	0M1!	4
SDI-12 Measurement #9			→	0M1!	5	

Tx#1	Battery Voltage	-	-	→	1M!	1
	4-20mA Water Level	-	-	→	1M!	2
	Volume Calc from 4-20mA WL	-	-	→	1M!	3
	Digital Input accumulator	-	-	→	1M!	4
	Last Measurement (hhmmss)	-	-	→	1M!	5
	SDI-12 Measurement #1 eg.	0M!	1	→	1M!	6
	SDI-12 Measurement #2			→	1M!	7
	SDI-12 Measurement #3			→	1M!	8
	SDI-12 Measurement #4			→	1M!	9
	SDI-12 Measurement #5			→	1M1!	1
	SDI-12 Measurement #6			→	1M1!	2
	SDI-12 Measurement #7			→	1M1!	3
	SDI-12 Measurement #8			→	1M1!	4
SDI-12 Measurement #9			→	1M1!	5	

Tx#2, #3,, #7 same as above

Rx	Battery Voltage	-	-	→	8M!	1
	4-20mA Water Level	-	-	→	8M!	2
	Volume Calc from 4-20mA WL	-	-	→	8M!	3
	Digital Input accumulator	-	-	→	8M!	4

2.2 Hardware Connections (Transmitter)

The WDC100 Transmitter can monitor 1 x 4-20mA signal + up to 9 x SDI-12 parameters (in a single transducer or scattered over 9 x transducers) + a digital input from say a TBRG rain gauge or a water flow meter + the battery voltage powering the transmitter itself.

The terminals are screwless, simply push the wire into terminal hole – you may need to depress the orange release lever if fine wire is used. This lever should be depressed to remove the wire.

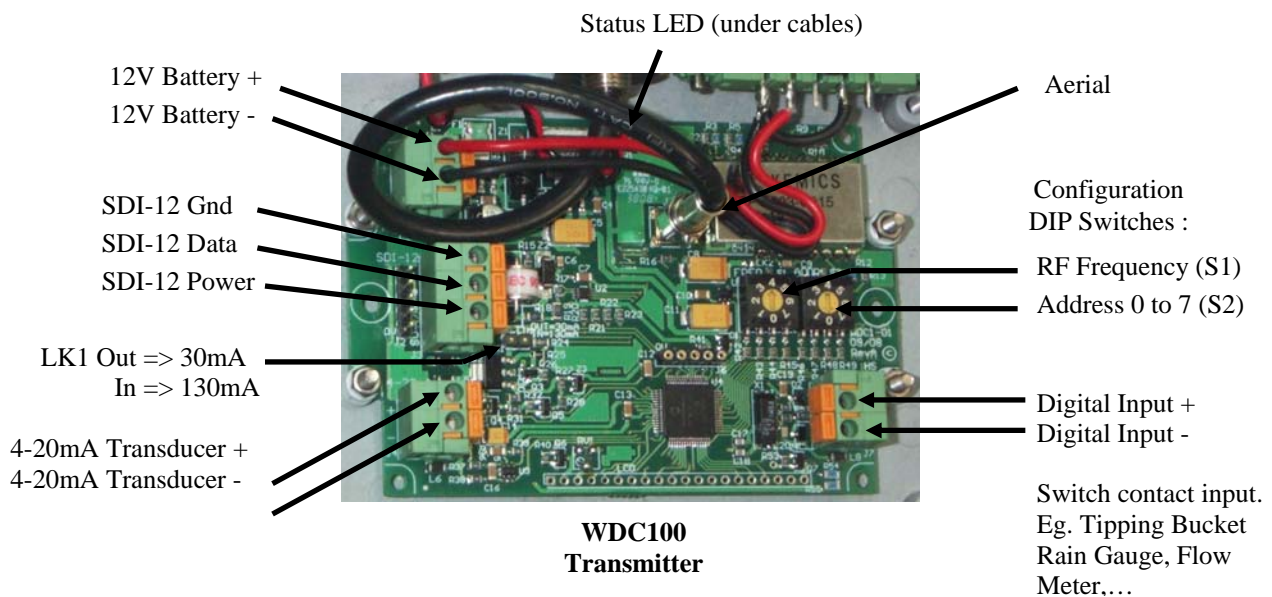

The SDI-12 Power signal AND the 4-20mA Transducer + signal are connected together on the PCB, and are switched 12V power. The combined current through these 2 terminals is current limited to 30mA when Jumper LK1 is “out” and current limited to 130mA when jumper LK1 is “in”.

When an SDI-12 measurement is required, the 12V power is switched to the SDI-12 Power signal for 2 seconds before the SDI-12 data commands are transmitted. If the SDI-12 transducer requires a constant 12V supply, then connect the SDI-12 device power to the Battery+ signal instead of using the SDI-12 Power terminal.

When a 4-20mA measurement is required, the 12V power is switched to the “4-20mA Transducer +” signal and left for the programmed “Warm Up” period before a measurement is taken.

Rotary Switch S1 sets the RF transmission frequency as follows :

(Mar-2013)	
Up to Tx S/W Rev1.3	Tx S/W Rev1.4 up
0 → 916.5MHz	0 → 904.5MHz
1 → 917.5MHz	1 → 907.5MHz
2 → 918.5MHz	2 → 910.5MHz
3 → 919.5MHz	3 → 913.5MHz
4 → 920.5MHz	4 → 916.5MHz
5 → 921.5MHz	5 → 919.5MHz
6 → 922.5MHz	6 → 922.5MHz
7 → 923.5MHz	7 → 925.5MHz

Rotary Switch S2 sets the WDC100 Transmitter address from 0 and 7.

NOTE : All other configuration settings are passed to the Transmitter from the central controller !!!

4-20mA Transducer

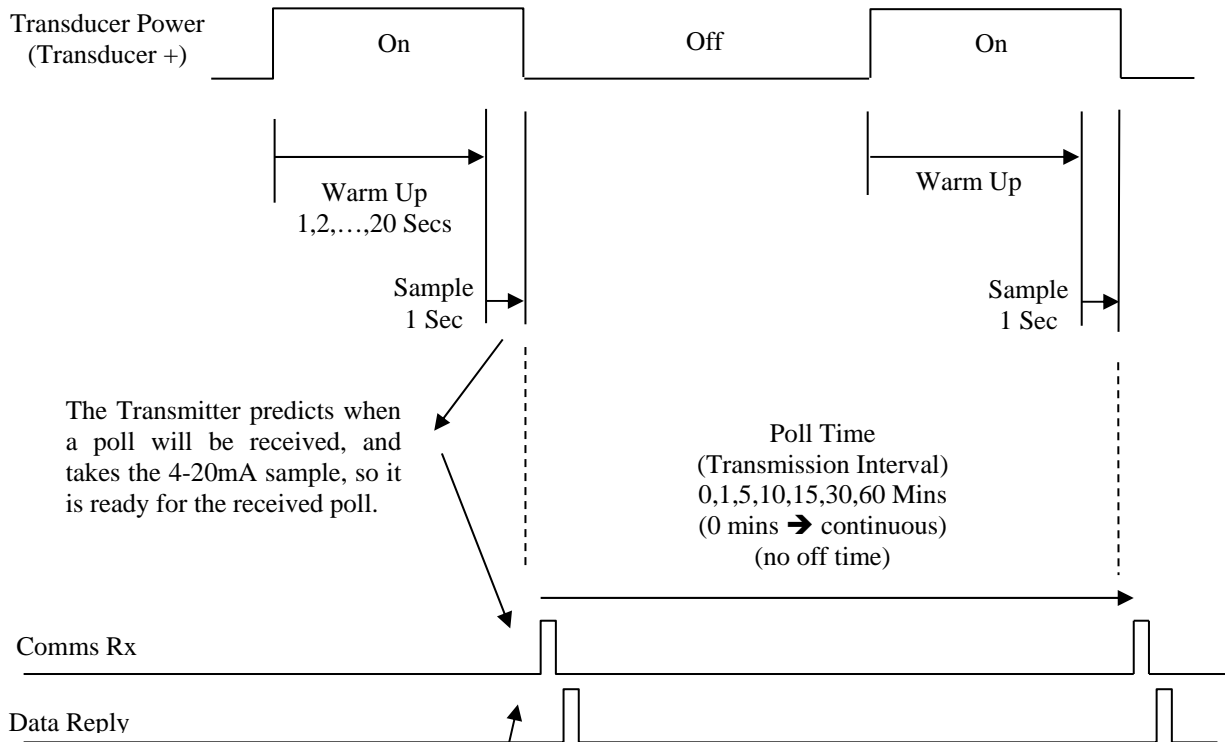

SDI-12 Transducers

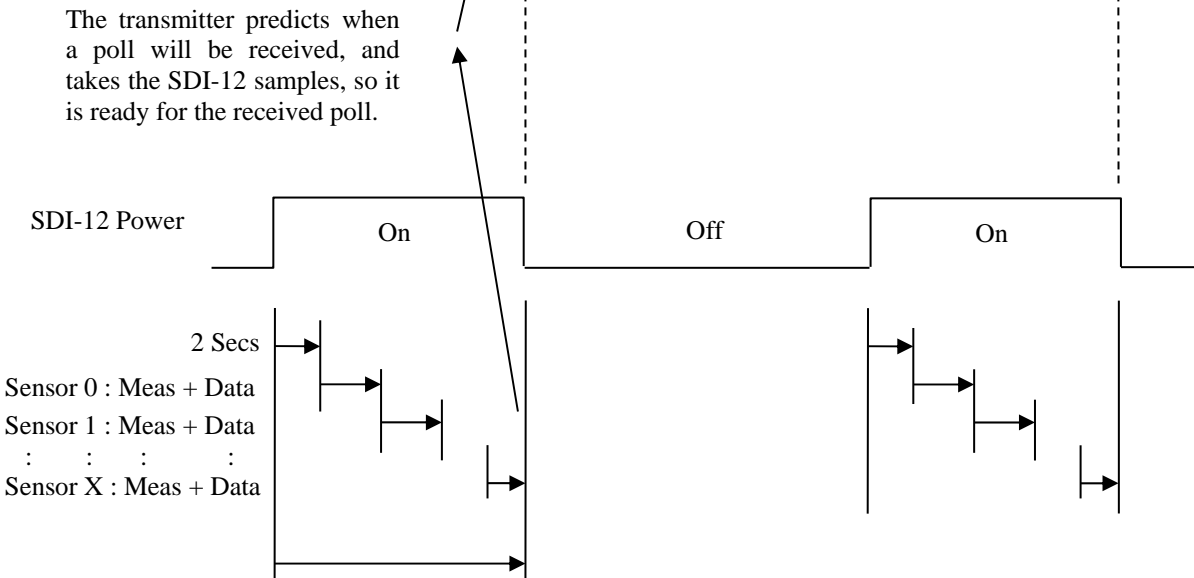

The time it takes to measure the SDI-12 samples depends upon the SDI-12 transducers used! The transmitter measures and saves away this time so it can predict when to start future samples.

2.3 Hardware Connections (Receiver)

The WDC100 Receiver collects data from up to 8 x WDC100 Transmitters and it can also monitor 1 x 4-20mA signal + a digital input from say a TBRG rain gauge or a water flow meter + the battery voltage powering the receiver itself.

The terminals are screwless, simply push the wire into terminal hole – you may need to depress the orange release lever if fine wire is used. This lever should be depressed to remove the wire.

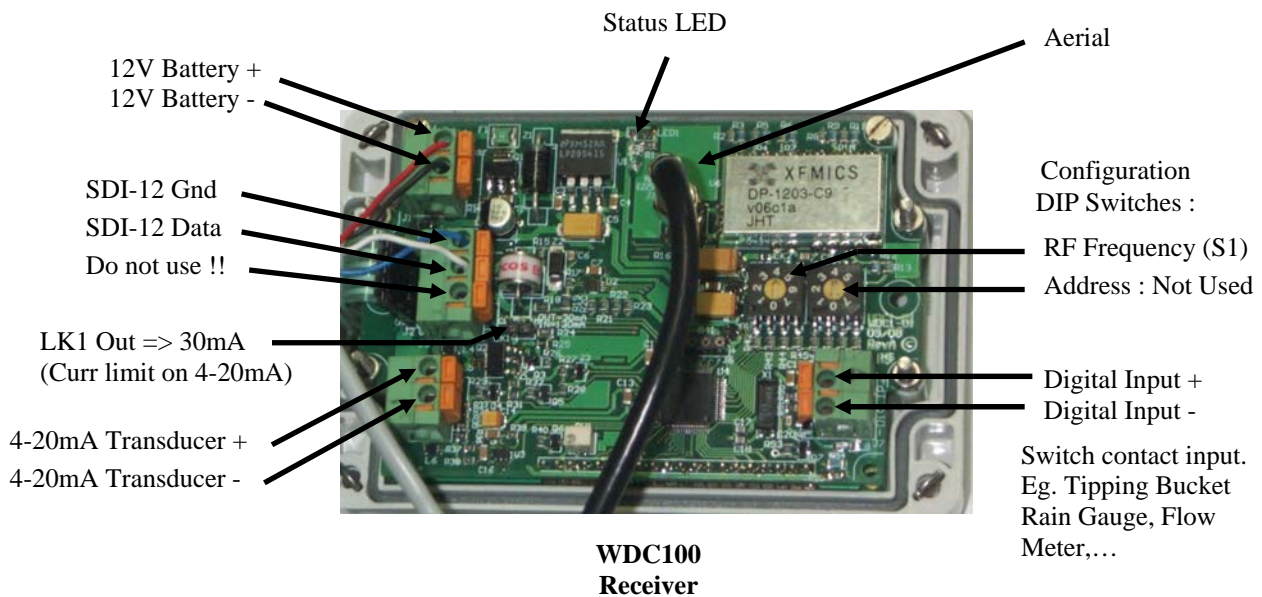

The “4-20mA Transducer +” is a switched 12V power signal and is current limited to 30mA when Jumper LK1 is “out”. When a 4-20mA measurement is required, the 12V power is switched to the “4-20mA Transducer +” signal and left for the programmed “Warm Up” period before a measurement is taken.

The SDI-12 Data and SDI-12 Gnd signals should be connected to the SDI-12 Data Logger. The WDC-100 Receiver will look like many different SDI-12 sensors.

NOTE :

Transmitter #0 will appear as SDI-12 Sensor address 0, Transmitter #1 will appear as SDI-12 Sensor address 1,(up to Transmitter #7), and the WDC100 Receiver will appear as SDI-12 Sensor address 8)

Rotary Switch S1 sets the RF transmission frequency as follows :

	(Mar-2013)
Up to Rx S/W Rev1.4	Rx S/W Rev1.5 up
0 → 916.5MHz	0 → 904.5MHz
1 → 917.5MHz	1 → 907.5MHz
2 → 918.5MHz	2 → 910.5MHz
3 → 919.5MHz	3 → 913.5MHz
4 → 920.5MHz	4 → 916.5MHz
5 → 921.5MHz	5 → 919.5MHz
6 → 922.5MHz	6 → 922.5MHz
7 → 923.5MHz	7 → 925.5MHz

NOTE : Each transmitter and receiver must be set to the same frequency setting.

Rotary Switch S2 sets the last WDC100 Transmitter that will be polled. Eg. If this switch is set to say 3, then the receiver will poll addresses #0, #1, #2 and #3

NOTE : All other configuration settings are set from the LCD and 4 buttons.

2.4 Antenna Mounting

Both the transmitter and receiver are supplied with a ground plane independent antenna that have 1.5dB gain. (The mounting thread of the antenna is connected to the battery –ve input.)

The antenna is mounted by :

- Hold the antenna coax cable firmly (1) and unscrew the antenna body (2).
- Remove the nut and washer from the antenna body and put onto the coax cable.
- Drill a 10mm mounting hole.
- Insert the coax cable through the mount hole – from the inside of the enclosure.
- Screw the antenna body back onto the coax cable – screw all the way in.
- Insert the antenna into the mounting hole and slide the washer and nut onto the antenna body and tighten the nut.

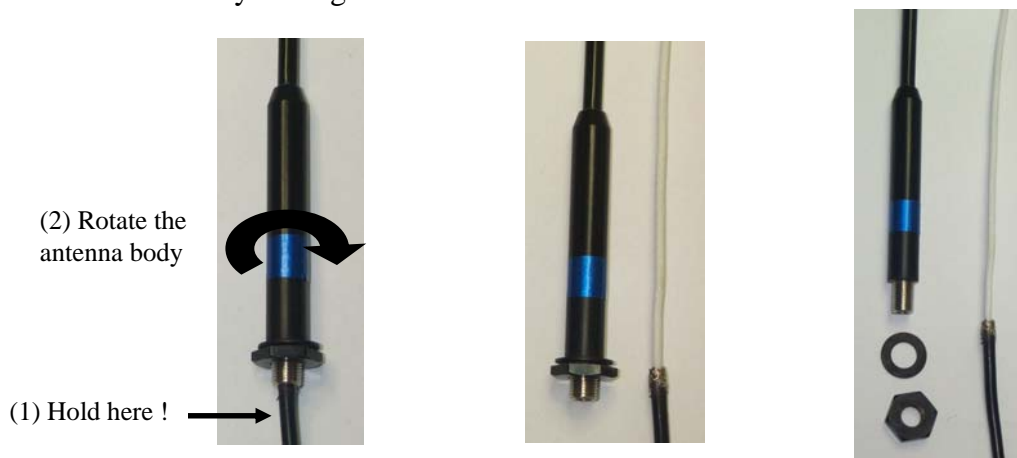

2.5 Power Supply

The Wireless Level Transmitter requires a 12V power source, such as a 7Ah lead acid battery. The transmitter has 4 basic states as shown :

Transmitter	Current Consumption
Sleep	0.20mA
Warm Up (4-20mA)	10mA + measured 4-20mA
SDI-12 Measure	10mA + SDI-12 sensor power
Waiting for RF Comms	20mA
Sending RF Reply (120mS)	80mA

← Mostly in this state !

The Wireless Level Receiver also requires a 12V power source, such as a 7Ah lead acid battery. The receiver has 6 states as shown :

Receiver	Current Consumption
LCD and backlight (B/L) off	20mA
LCD and B/L off + Warm Up (4-20mA)	20mA + measured 4-20mA
LCD and B/L off + Transmitting RF (50mS)	80mA
LCD and B/L on	60mA
LCD and B/L on + Warm Up (4-20mA)	60mA + measured 4-20mA
LCD and B/L on + Transmitting RF (50mS)	120mA

← Mostly in this state !

2.6 Menu Navigation

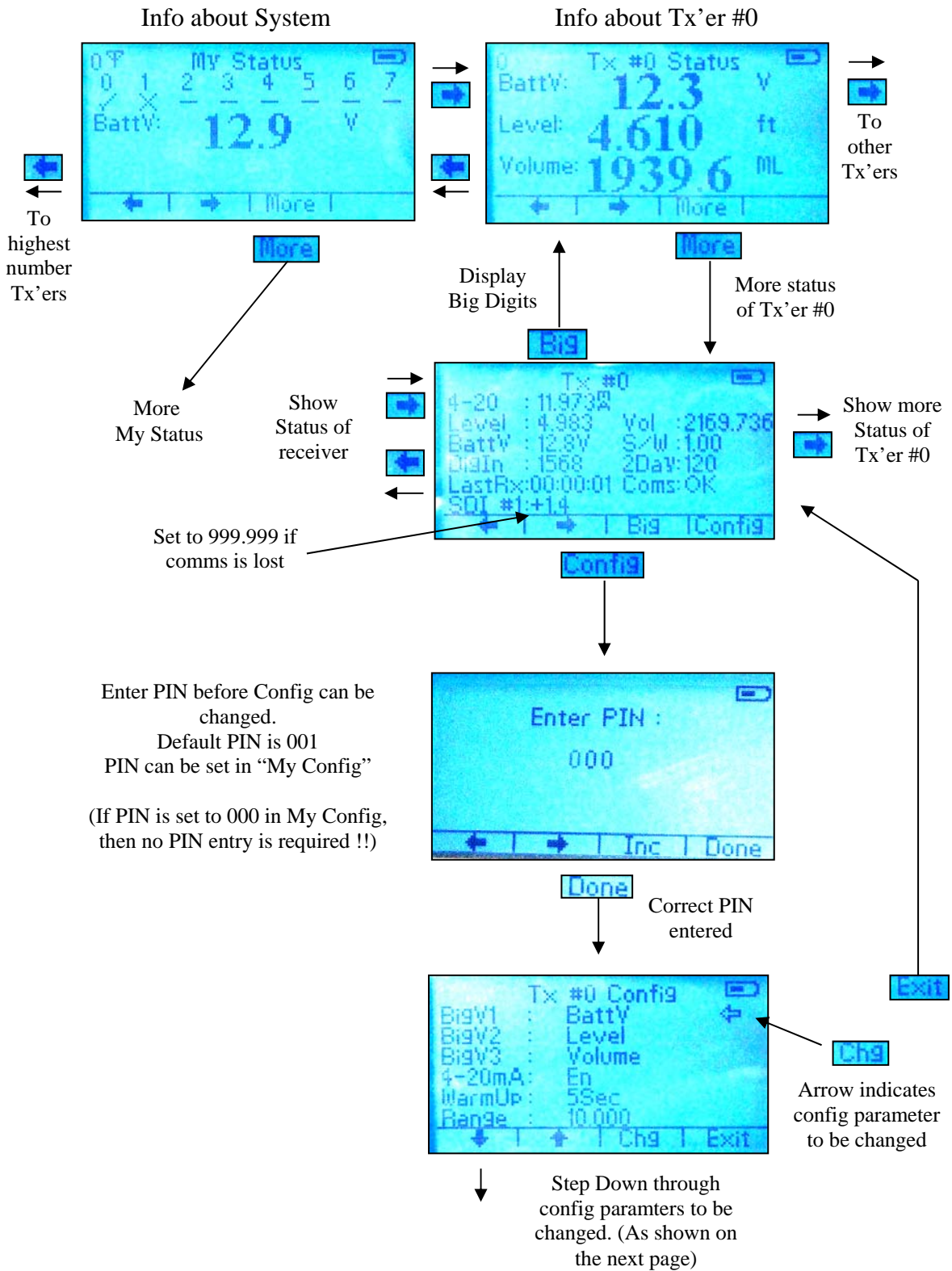

2.7 Configuration

The configuration of all Transmitters is performed through the receiver LCD and buttons, and then sent to the transmitter during the next poll sequence.

Both the Receiver and each Transmitter must be configured separately.

Receiver Configuration “My Config”

Arrow indicates position to change Chg

0 My Config

BigV1 : BattV

BigV2 : None

PIN : 001

4-20mA: En

WarmUp: 5Sec

Range : 10.000

↓ ↑ Chg Exit

SetLvl : -2.500

Units : m

CalcOfs: 0.000

ZerOfs : 30Min

↓ ↑ Chg Exit

Digio : En-I/P

DigSize : 0.200

Preset : 0.000

DigUnits: mm

Volume : 4-20ip+NDP

VolUnits: kl

↓ ↑ Chg Exit

Point	Level	Volume
0 :	0.00	0.0
1 :	1.20	200.0
2 :	2.00	460.0
3 :	2.60	750.0
4 :	3.00	1000.0

↓ ↑ Chg Exit

Point	Level	Volume
5 :	4.00	1500.0
6 :	5.00	2180.0
7 :	6.00	2790.0
8 :	9.20	4850.0
9 :	9.20	4850.0

↓ ↑ Chg Exit

Tx#	En/Dis	Tx#	En/Dis
0:	-	4:	-
1:	-	5:	✓
2:	✓	6:	-
3:	-	7:	-

↓ ↑ Chg Exit

Select Big Values to be displayed

Set the new PIN number (when set to “000, PIN entry is disabled)

Configure 4-20mA input. Enable, warmup period, transducer range, set transducer level from gauge plate, set units, zero the offset.

Set polling interval
0Min → continuous (for testing)

Configure Digital Input or Output and which Tx operates it. Input : increment for each event, preset starting level, set units.

Configure Volume calculation from 4-20mA water level. (Also allows Decimal Point (DP) or No Decimal Point (NDP)), set units.

Define the 10 point linear interpolation table.

Configure which of the Transmitters 0 to 7 are Enabled / Disabled.

Transmitter Configuration

Arrow indicates position to change

Select Big Values to be displayed

Configure 4-20mA input. Enable, warmup period, transducer range, set transducer level from gauge plate, set units, zero the offset.

Set polling interval
0Min → continuous (for testing)

Configure Digital Input. Enable, increment for each event, preset starting level, set units.

Configure Volume calculation from 4-20mA water level or SDI-12 input #1, (DP=Decimal Place, NDP=No Decimal Places) set units, define points #0 to #9 for linear interpolation table.

Number of SDI-12 data points to be monitored

Configure SDI-12 devices that are monitored.

An offset may be added to SDI-12 input #1 only. This Config screen shows the Raw Data, the Offset to be added and the final Adjusted Data. Press "Chg" to edit the offset.

Up to 9 x SDI-12 data inputs can be monitored by each OutPost Transmitter. These data points may be within the same SDI-12 address, or they may be split up over several SDI-12 addresses.

Example :

Data Input #1 may be from SDI-12 Address 1 Measurement 5 Data Point 1

Data Input #2 may be from SDI-12 Address 1 Measurement 5 Data Point 2

Data Input #3 may be from SDI-12 Address 3 Measurement Data Point 1

:

3. Operation

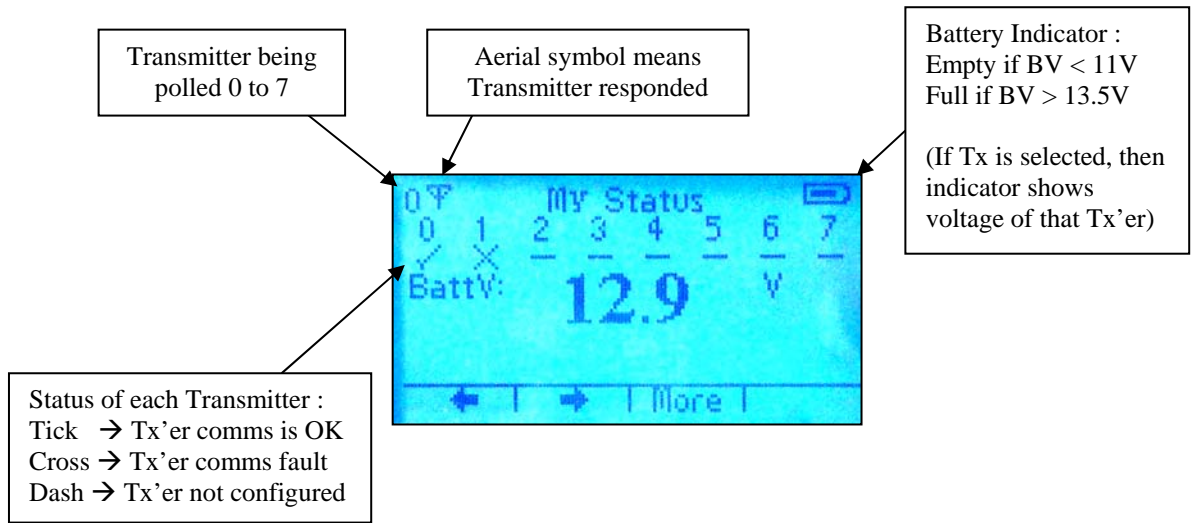

Polling vs Power Consumption

When a Transmitter is set to poll continuously, it will continuously take measurements from any sensors connected, and the receiver will poll it continuously. In this mode the Transmitter will never go to sleep, and will consume the maximum power. It is recommended that this mode be used when testing the OutPost System.

When the OutPost Transmitter is to be put into service, set the specific Transmitter Poll time to 1min, 5min, 10min, 15min, 30min or 60min. When the Transmitter is in between polling, it goes to sleep and consumes 0.2mA. This is the preferred mode of operation.

If the poll time is set to a period greater than 1 minute, the transmitter will still wake up every minute and respond to a Receiver poll, so that the Transmitter and Receiver stay in synch. The Transmitter will not take a measurement during these synch polls.

When the Transmitter goes to sleep, it continually monitors the time, and knows when the Receiver is going to poll it for the next sensor data. The Transmitter also knows how long it will take to gather data from the sensors, and it therefore wakes up prior to the poll, takes the sensor measurements just in time for the poll from the Receiver.

3.1 Transmitter LED

LED	Description
Flashes every 1 secs	Transmitter is asleep
Bright Flash	Transmitting result

3.2 Displaying Water Volume

The WDC100 has the facility to display the water volume (of a reservoir) as a function of the 4-20mA water level (Receiver S/W Rev 1.2 and below). In S/W Rev 1.3 the water volume could also be calculated from the SDI-12 #1 variable. Some customers had problems getting a 4th order polynomial to fit their data points, so a new method was introduced in S/W Rev 1.4 See **Appendix A** for details on how to derive the appropriate polynomial type equations and hence the terms of the 4th order polynomial Poly0 thru to Poly4. (See **Appendix B** for the method to do a 10 point linear interpolation level to volume mapping.)

4th Order Polynomial – (S/W Rev 1.3 and lower) - See Appendix A

The formula generated in the example is :

$$\text{Water Volume} = 0.8065 x^4 - 18.957 x^3 + 165.76 x^2 - 19.588 x + 0.000$$

(where x is the water depth in metres)

For this example, the polynomial terms entered into the WDC100 are as follows :
(Please note the sign of each term !!!!!)

- Poly0 = 0.000 (term for x⁰, which is the intercept)
- Poly1 = - 19.588 (term for x¹, which is just x)
- Poly2 = 165.760 (term for x²)
- Poly3 = - 18.957 (term for x³)
- Poly4 = 0.8065 (term for x⁴)

The Volume display option must first be enabled, so the Poly0 to Poly4 configuration appears.

10 Point Linear Interpolation – (S/W Rev 1.4 and higher) - See Appendix B

This is the method used in all new products supplied. This Level to Volume mapping can be made to fit any relationship.

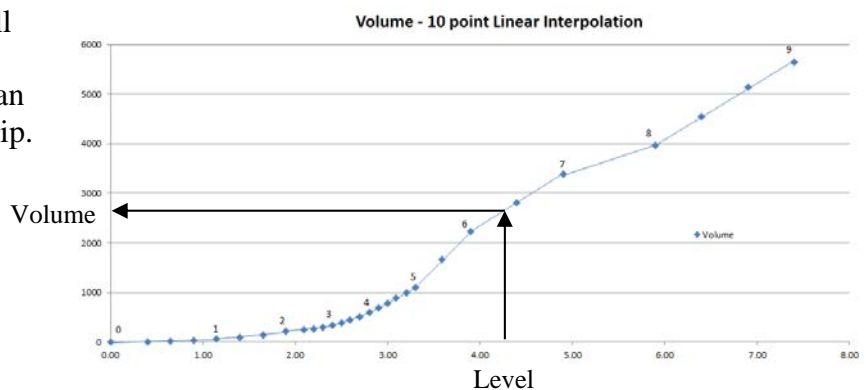

By using the “Set Level” menu item, you can preset various levels and hence check the Water Volume. As the water level now changes between 0.000m and 10.000m the water volume of the reservoir will be displayed.

PLEASE NOTE : The water volume is **not exact**, but it is a very good approximation.

4. Specification

4.1 Hardware Specification

Transmitter 4-20mA Input	16 bit resolution : 8 samples over 1 sec
Transmitter Inputs	1 x 4-20mA : 1 x Digital Input : 9 x SDI-12 inputs : Volume Calculated from 4-20mA or SDI-12 #1 Water Level Battery Voltage
Receiver Inputs	1 x 4-20mA : 1 x Digital Input : Battery Voltage : Volume Calculated from 4-20mA Water Level Only
Indicators	WDC100 Transmitter - Status LED indicator WDC100 Receiver – 128 x 64 Graphics LCD
Controls	WDC100 Receiver – 4 x Pushbuttons
Connections	Screwless Terminals
Radio Frequency	916.5 to 923.5MHz (in 1MHz steps) Prior to Mar 2013 904.5 to 925.5MHz (in 3MHz steps) Mar-2013 Onwards
Transmit Power	10mW
Range	1km (0.62 miles) line of sight
Dimensions	125mm x 80mm x 57mm (L x W x D)

Appendix A Creating the Level to Volume Formula

The WDC100 has the facility to display the water volume (of a reservoir) as a function of the water level. The function originally implemented was a 4th order polynomial. (Receiver S/W Rev 1.3 and lower) This method is kept here for completeness - some customers had problems getting the polynomial to fit their set of points, so a different method has been introduced in Receiver S/W Rev 1.4 April 2012) and above – See Appendix B.

This appendix shows how to generate the formula from a “level : volume” data table.

After a site survey, a table of data equating water level (in metres) to water volume (in mega-litres) should be entered into an Excel spreadsheet as shown

(The water volume units can also be entered into the WDC100. eg kL → Kilolitres or ML → MegaLitres)

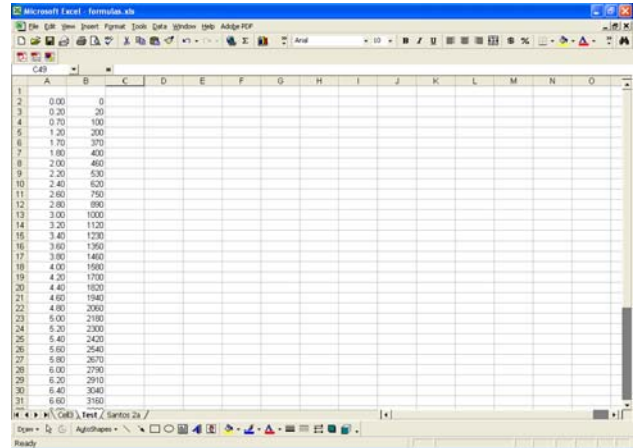

Select the data, then click on the “Chart Wizard” or select the menu item “Insert – Chart”.

Click on XY (Scatter) and click finish.

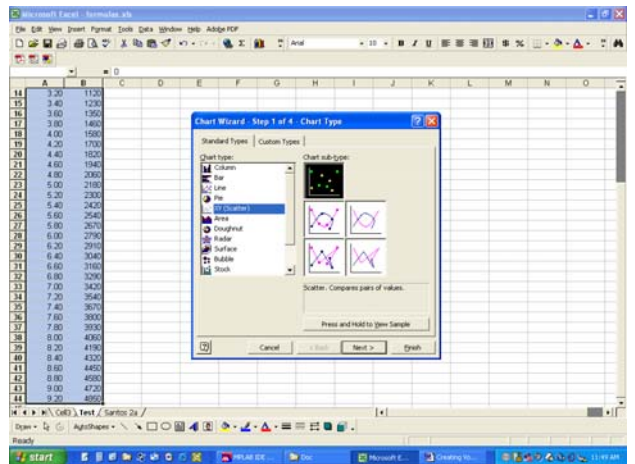

This will automatically create a graph of points relating water level (x axis) to the water volume (y-axis).

Position and size the graph on the spreadsheet page.

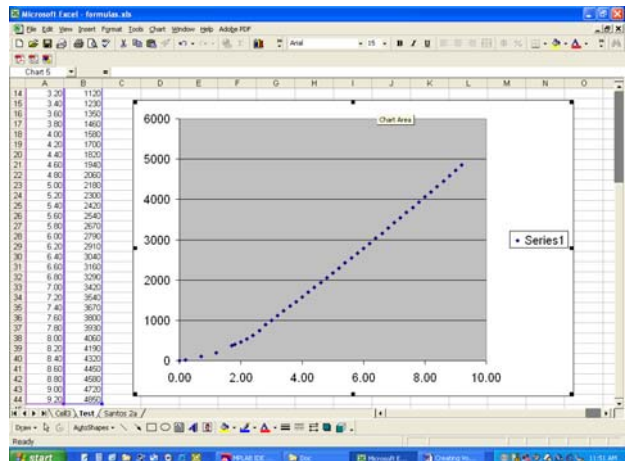

Click on one of the graph points, then right click and select “Add trendline...”

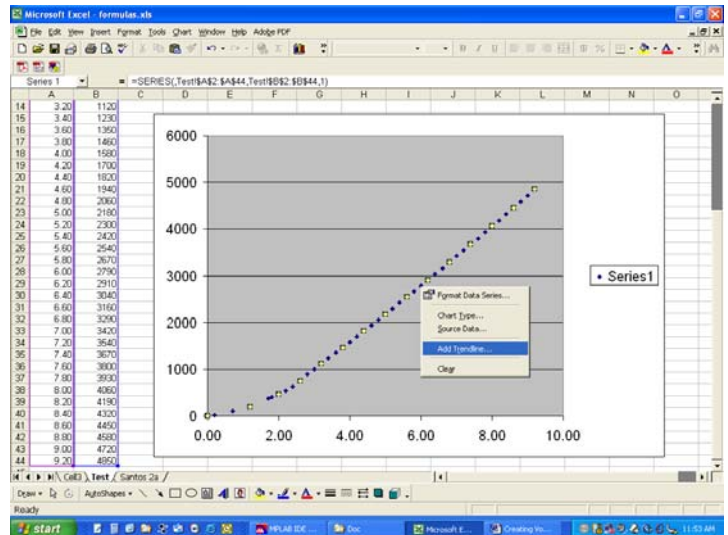

Click on Polynomial and increase “Order” to 4 (to create a 4th order polynomial)

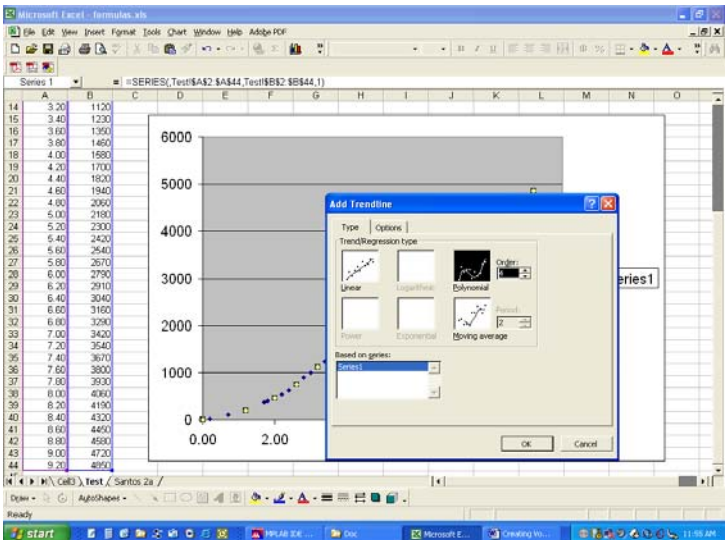

Click on the “Options” tab.

Select “Set intercept =” and then enter the water volume when the water level is 0.00m

Select “Display equation on chart”

Click OK

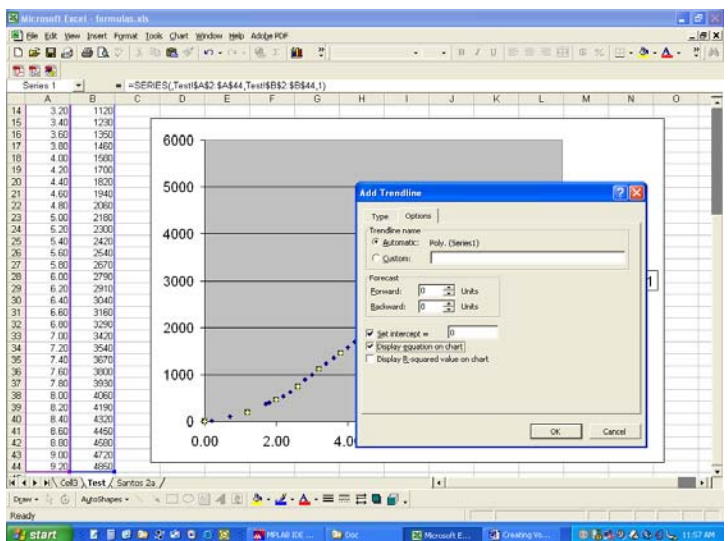

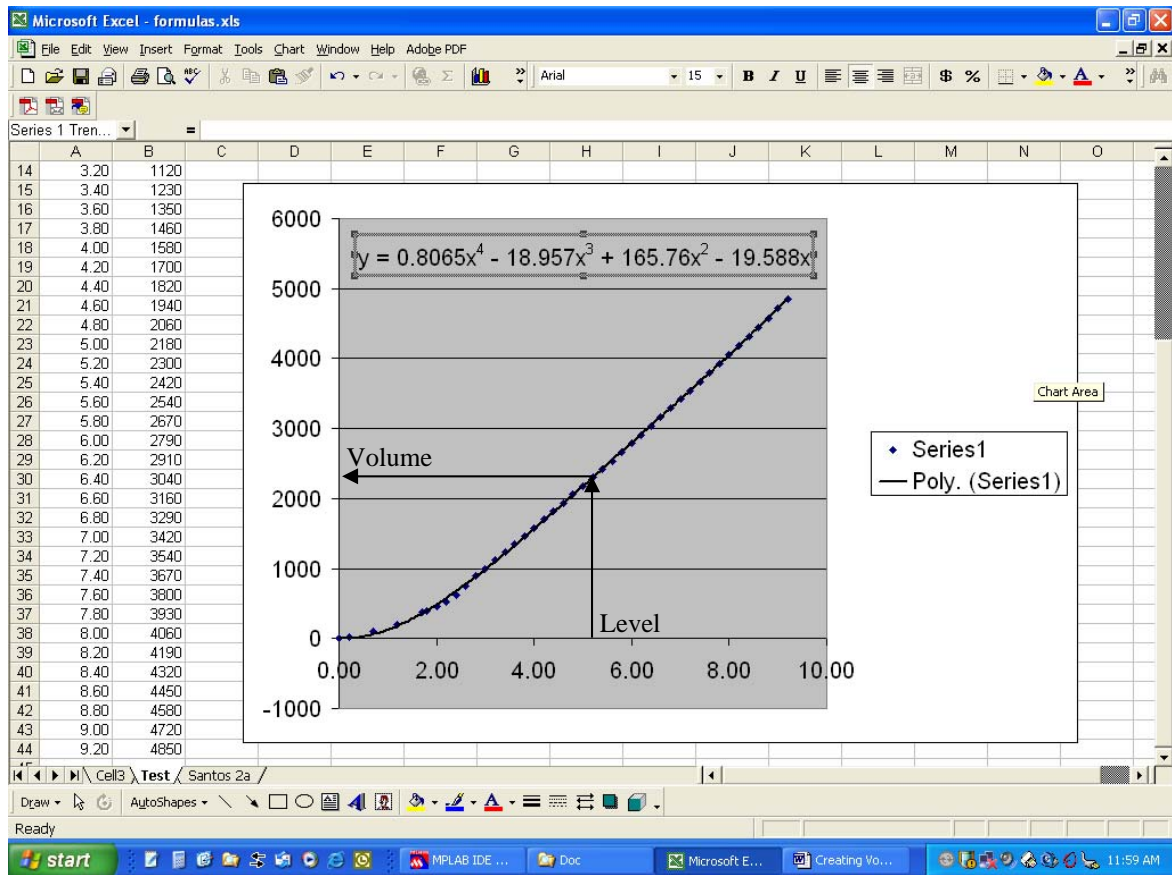

The line drawn on the chart is the 4th order polynomial. You should get a good idea of how well the formula fits the tabled data.

The formula generated in this case is :

$$\text{Water Volume} = 0.8065 x^4 - 18.957 x^3 + 165.76 x^2 - 19.588 x + 0.000$$

(where x is the water depth in metres)

For this example, the polynomial terms entered into the WDC100 are as follows :
(Please note the sign of each term !!!!!)

- Poly0 = 0.000 (term for x⁰, which is the intercept)
- Poly1 = - 19.588 (term for x¹, which is just x)
- Poly2 = 165.760 (term for x²)
- Poly3 = - 18.957 (term for x³)
- Poly4 = 0.8065 (term for x⁴)

As the water level now changes between 0.000m and 10.000m the water volume of the reservoir will be displayed.

PLEASE NOTE : The water volume created from this 4th order polynomial is **not exact**, but it is a very good approximation.

Appendix B Creating the Level to Volume Mapping

Some customers found it difficult to get the 4th Order Polynomial described in Appendix A, to accurately fit their data – as shown on the Excel spreadsheet / graph below.

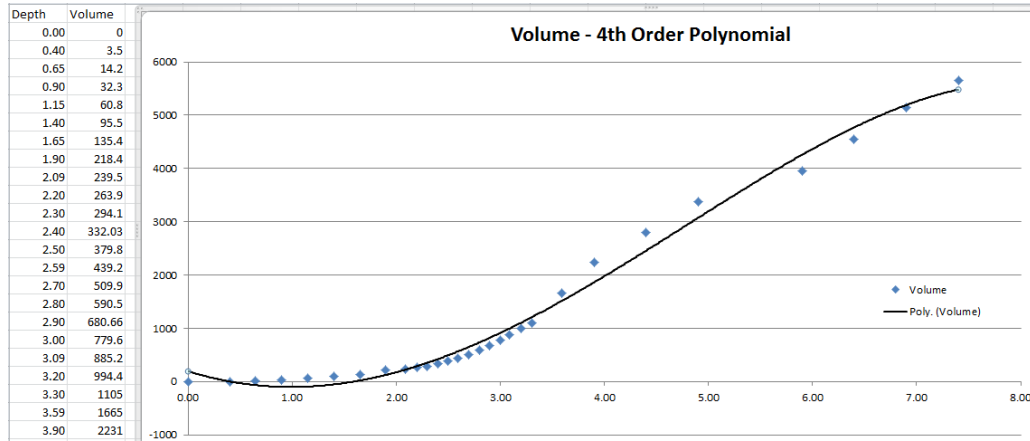

So we decided to implement a new method “a 10 point linear interpolation”. That is : Pick any 10 points and draw a straight line between each point - this will better fit **any** set of points. (The graph below shows the same points as above, but with the 10 point method)

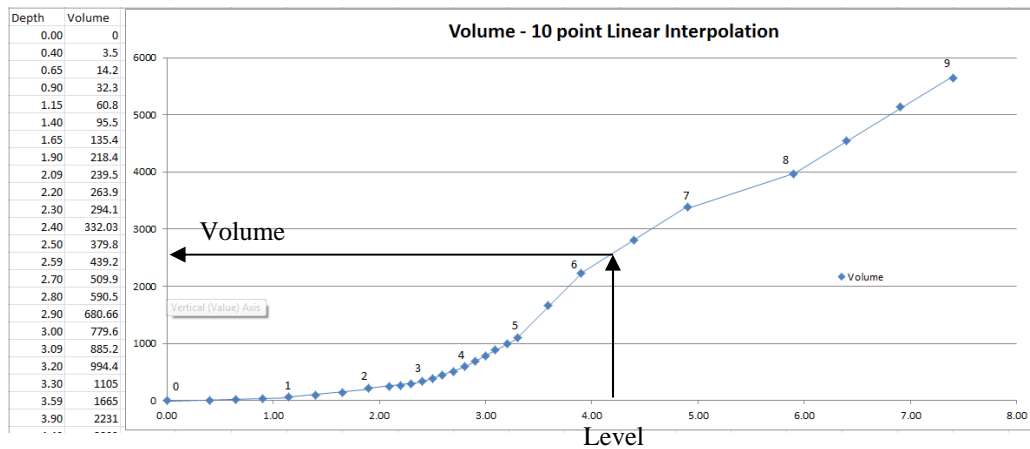

So the above 10 points to be entered into the Outpost are :

Point #	Level (m)	Volume (kL)
0	0.00	0.00
1	1.15	60.8
2	1.90	218.4
3	2.40	332.0
4	2.80	590.5
5	3.30	1105.0
6	3.90	2231.0
7	4.90	3380.0
8	5.90	3963.0
9	7.40	5650.0

NOTE : If the data fits nicely in only 8 points say, then repeat the last point 3 times until all 10 points are used!

The 2 x Outpost configuration screens where the data is entered are shown below :

Point	Level	Volume
0 :	0.00	0.0
1 :	1.15	60.8
2 :	1.90	218.4
3 :	2.40	332.0
4 :	2.80	590.5

Point	Level	Volume
5 :	3.30	1105.0
6 :	3.90	2231.0
7 :	4.90	3380.0
8 :	5.90	3963.0
9 :	7.40	5650.0

There is also a new Windows tool called “OutpostConfig” that also allows this table to be entered from a PC, or read from a file, or saved to a file !

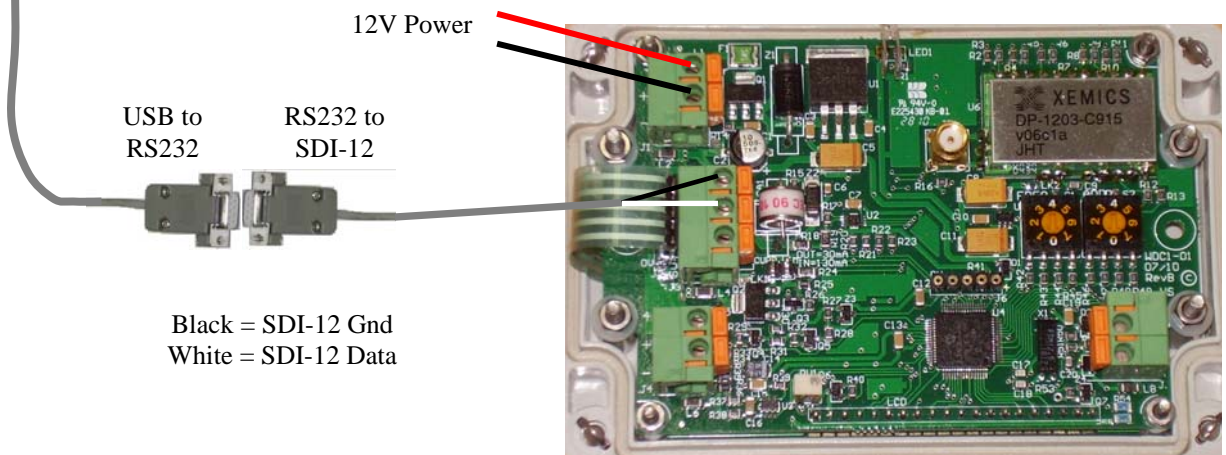
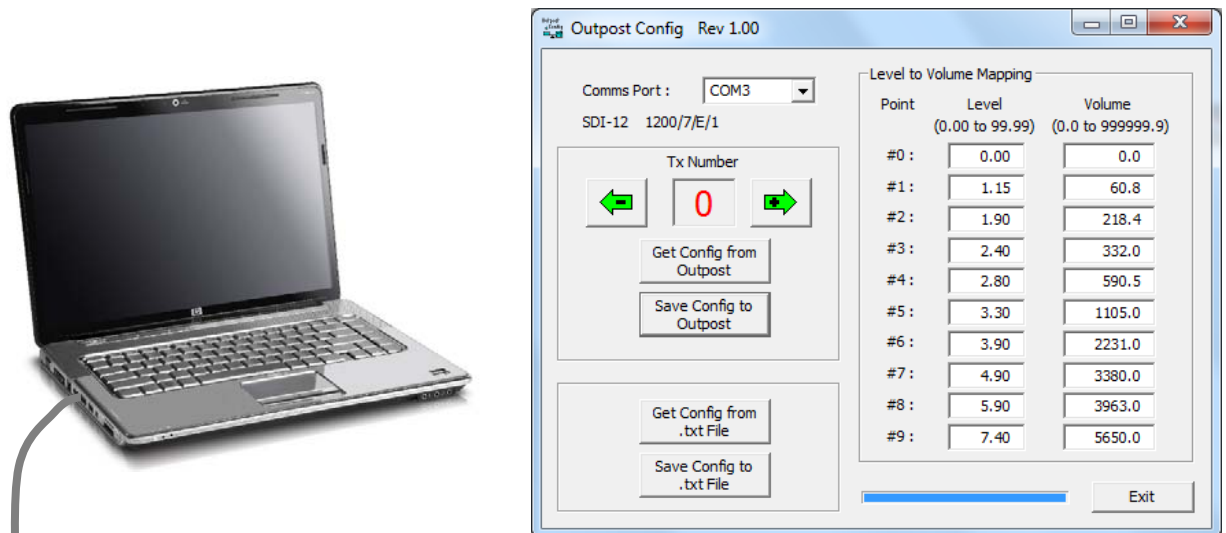

Outpost Receiver

All configuration is held in the Outpost Receiver, so connect a PC to the receiver via an RS232 to SDI-12 adapter as shown, and start the OutpostConfig Application.

1. Select the RS232 Comm Port.
2. Select the Tx Number that you wish to configure (0 to 7 or Rx)
3. Click on “Get Config from OutPost”
4. Enter the Level to Volume Mapping table.
5. Click on “Save Config to OutPost”

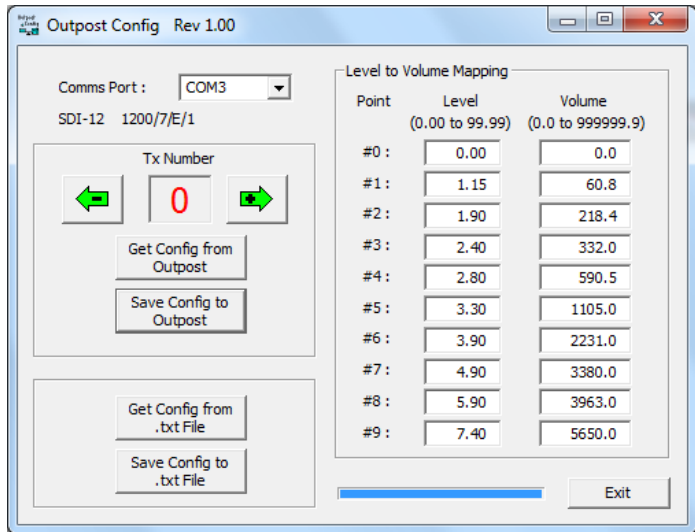

If you wish to also save the data to a file, click on “Save Config to .txt File”

The file format looks like this :

Any line starting with // is a comment.
 The Level can be 00.00 through to 99.99
 The Volume can be 0.0 to 999999.9
 The data is separated by a comma.

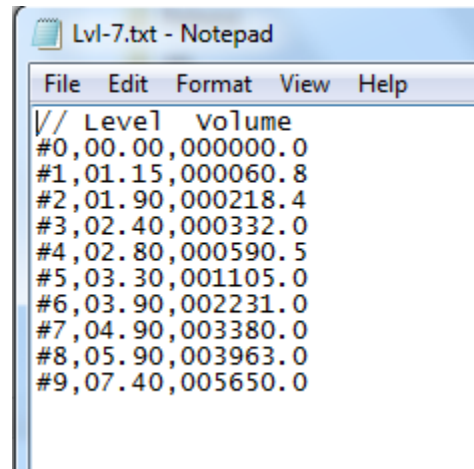

You can also create your own files by simply typing them into Notepad in this format, and naming them “filename.txt”. The use the button “Get Config from .txt File” to load up the table.

All the other Outpost Configuration must be done from the pushbuttons and LCD.

The Volume can be calculated from 2 inputs, either the 4-20mA input or the SDI-12 #1 input, as set by the “Volume” parameter. The resultant volume is displayed with either Decimal Places (DP) or No Decimal Places (NDP)

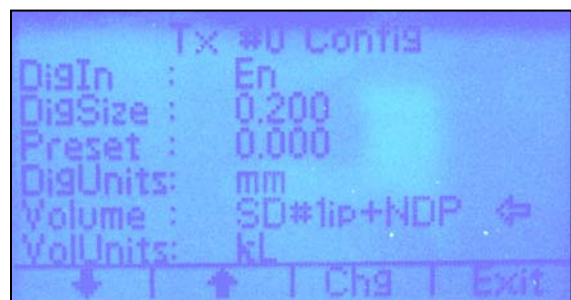

Appendix C Buoy Breather Bag Setup

We have changed the transducer venting in the Buoy for several reasons :

- Vented transducers always have a problem with moisture collecting in the vent tube.
- Venting the vent tube to atmosphere means that the electronics PCB is also vented to atmosphere, which in a marine environment will ultimately lead to corrosion forming.

We have solved these problems by keeping the electronics in a completely sealed enclosure AND

Providing a sealed system over the vent tube, but keeping the vent tube pressure matching atmospheric pressure.

By using a very soft, sealed, plastic bag (breather bag) over the end of the vent tube, the atmospheric pressure outside the bag will be exactly the same as the pressure inside the bag – but moisture is kept outside the bag. (A small silica gel bag is placed inside the sealed plastic bag when it is manufactured, to absorb any moisture that enters the system.)

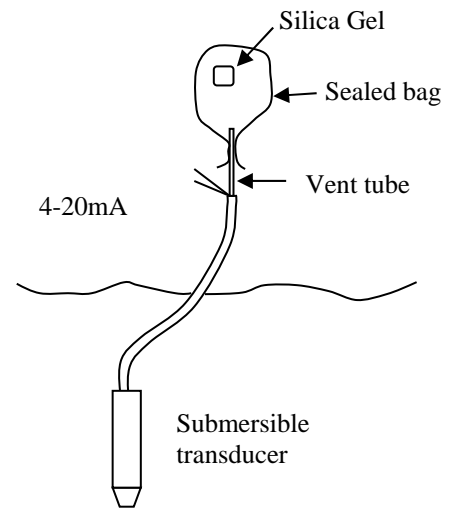

The system is shown on the left with the cover removed (The cover is shown removed, for your information only - you do not need to ever remove the plastic box cover !)

To operate correctly, the breather bag needs to have the correct amount of air injected :

- too much air and the system will become pressurised if the temperature increases or the atmospheric pressure falls
- too little air and the system will become a vacuum if the temperature falls or the atmospheric pressure increases.

The calculated amount of air inside the breather bag for 50m of vented tube is about 120mL.

The following pages describe how to inject this amount of air into the breather bag.

1. Remove the 4 corner screws securing the **metal** lid to the electronics enclosure.
A plastic tube from the breather bag enters the lid as shown. Remove the joiner and smaller tubing.



2. Firstly, we have to remove all the air from the breather bag.
Expel all the air from the supplied syringe,
Connect the syringe to the plastic tube as shown,
Pull the syringe plunger to remove the air from the breather bag – repeat until all the air is removed from the bag.
3. Remove the syringe, set the plunger to the 60mL mark, connect the syringe to the tube and inject the 60mL of air into the breather bag – Repeat this so that a total of 120mL of air is injected into the breather bag.
4. Remove the syringe, and reconnect the joiner and smaller tubing as shown.



5. After feeding the INW submersible cable through the cable gland at the base of the electronics enclosure, fit a large cable tie and do it up tight as a strain relief. Now do up the cable gland to secure the submersible cable.

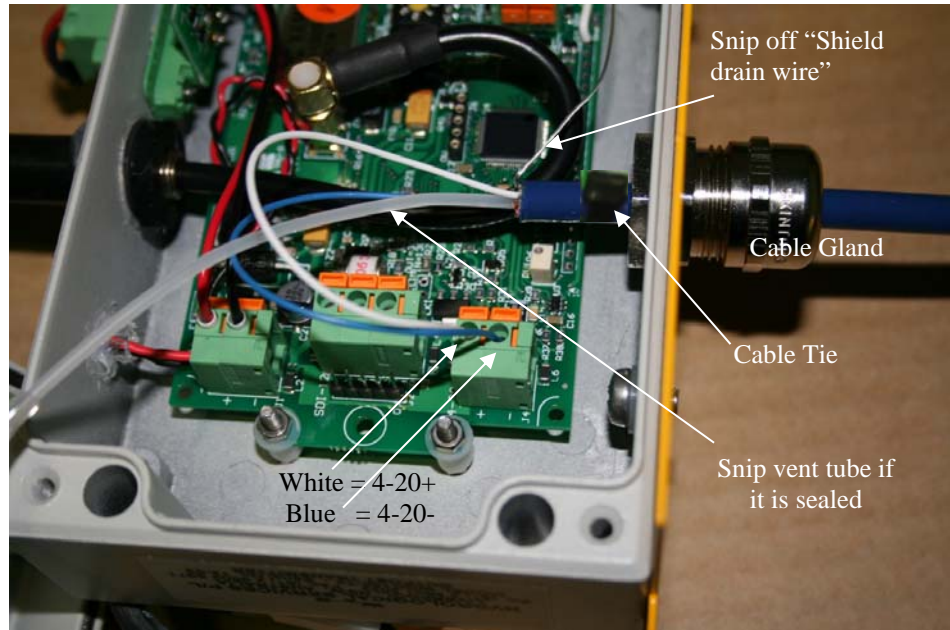

6. The brand new INW submersible transducer may have the vent tube crimped and sealed – so the end may need to be snipped off with some side cutters.
7. Fit the breather bag smaller tubing over the vent tube – finalising the sealed vent system.
8. If it is not done already, snip off the “shield drain wire”.
9. Fit the blue wire into 4-20– and fit the white wire into 4-20+ terminals as shown.
10. Fit the enclosure metal cover and do up the 4 x securing screws.
11. When deploying the buoy, make sure the 12V battery is connected, and the solar panel on the lid is wired to the solar+ and solar- terminals on the plug-in green terminal block. (The solar is now switched electronically inside the transmitter, so the 12V battery is never overcharged.)

Appendix D Sending Custom SDI-12 Commands

Once a system is installed and operating, it may be convenient to remotely access a sensor's SDI-12 custom command set - to adjust a parameter, read an internal setting etc.

Custom commands have been added to the Outpost Receiver, to allow any SDI-12 command (up to 30 chars long) to be passed through the radio network and through an Outpost Transmitter to a remote SDI-12 device and the SDI-12 response (up to 30 chars long) passed back through the network. (The SDI-12 sensor doesn't even need to be configured in the Outpost system - for example, if a sensor is installed with an incorrect SDI-12 address, a command may be sent to the SDI-12 sensor to change its address.)

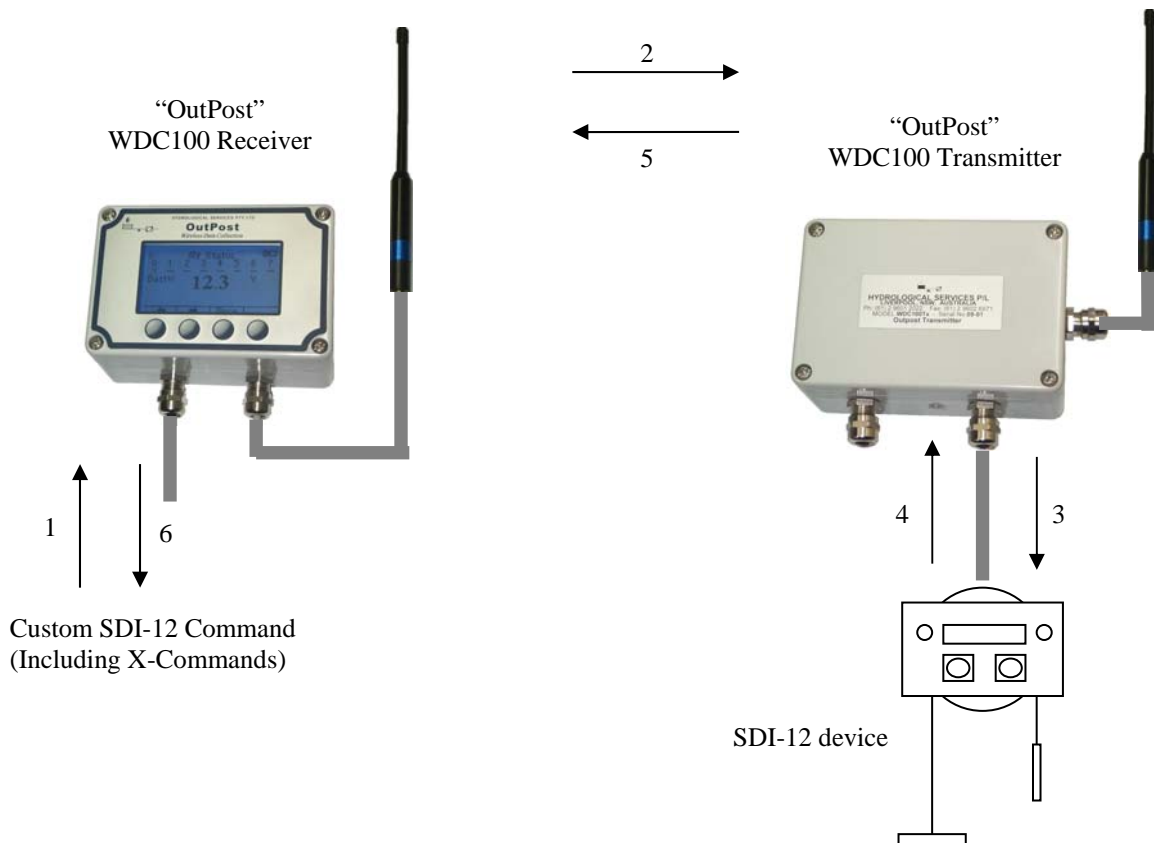

There are 2 ways this can be facilitated, the first is through a custom PC application called "Outpost Express" connected directly to the Outpost Receiver – and the second is by implementing custom commands through the attached Data Logger of RTU.

Method 1 :

Connect a PC to the Outpost Receiver via an “RS232 to SDI-12” adapter (available from HyQuest Solutions) and run the application supplied, called “Outpost Express”. (This application will encapsulate the SDI-12 command and monitor its progress through the Outpost network)

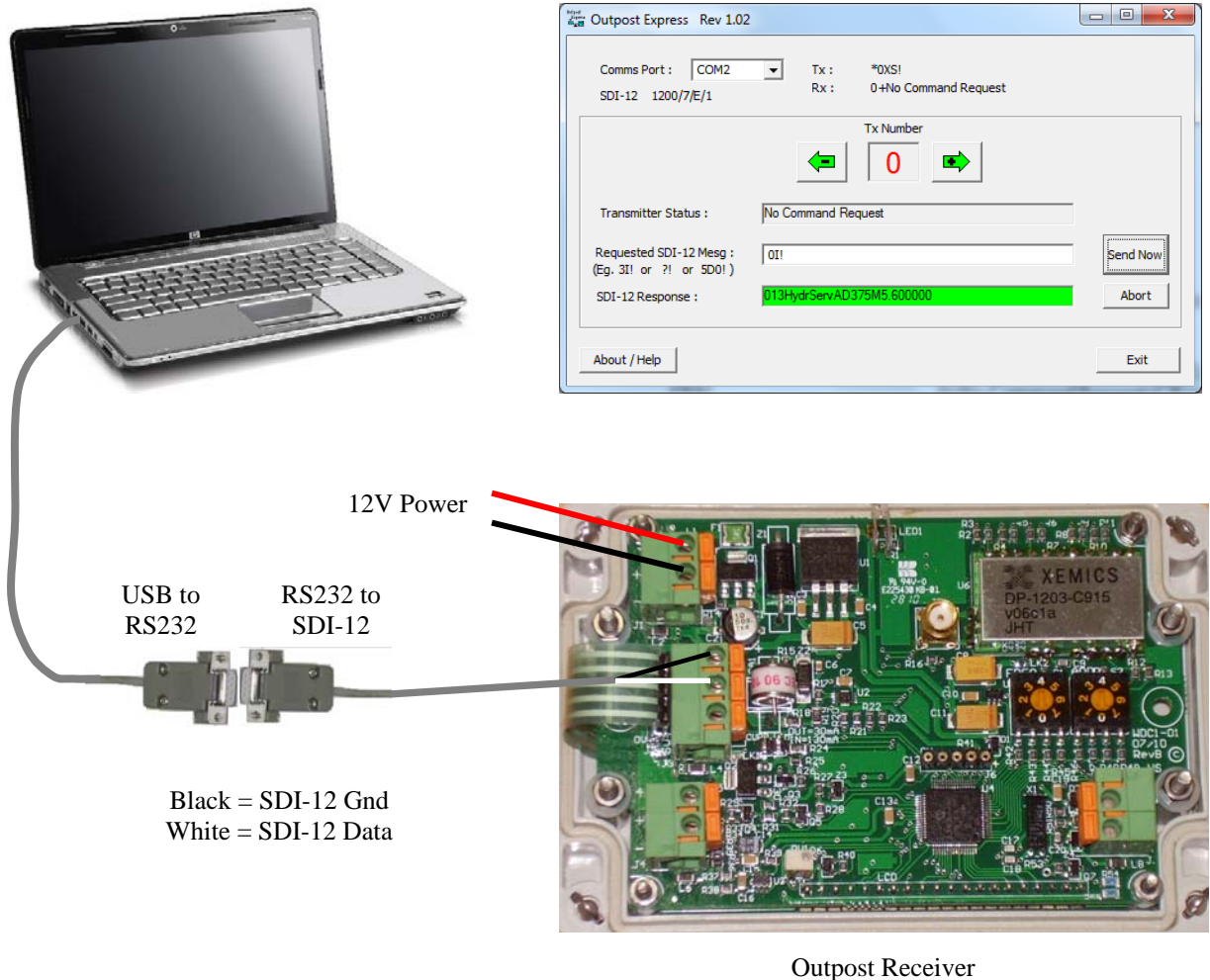

Once communications to the Outpost Receiver are established, one of the 8 Outpost Transmitters can be selected and a specific SDI-12 command typed – as long as it starts with an SDI-12 address 0 to 7 and ends with an exclamation mark ! the command will be accepted. This command will be passed through the radio network to the remote sensor, and the response passed back through the radio network to the Outpost Express application.

Status of the message progress will be displayed in the “Transmitter Status” field. When and if the command is successful, the response is displayed in the “SDI-12 Response” field highlighted in green.

To operate the “Outpost Express” application, first select the comm port that is connected to the RS232 to SDI-12 adapter. (If unsure of the COM number, select them one at a time until comms is achieved!)

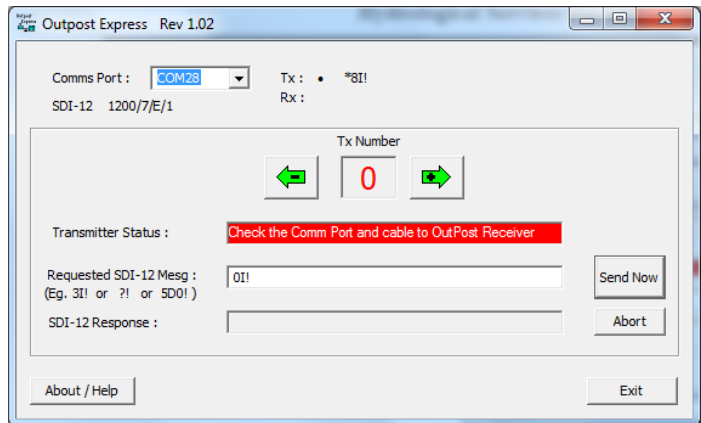

The application displays status information :

- Red highlighted text indicates there is a problem with the hardware.
- Red text indicates there is a problem with what you are attempting to do.
- Black text indicates everything is OK.

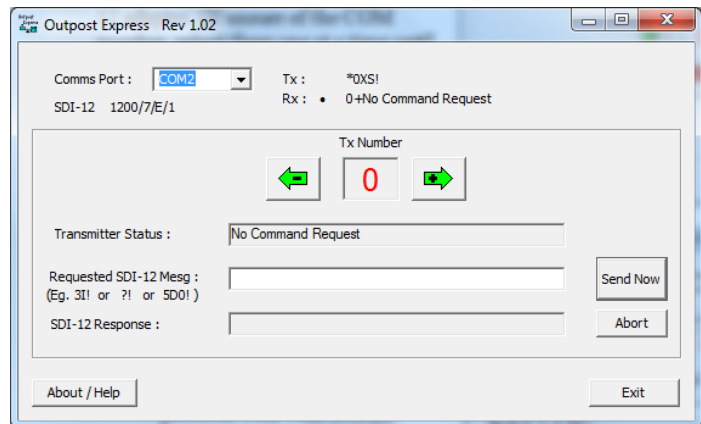

Use the Green arrows to select the transmitter number that the SDI-12 device is connected to. (0 to 7)

(The software revision of the Receiver and Transmitter are also individually checked to make sure they support this feature.)

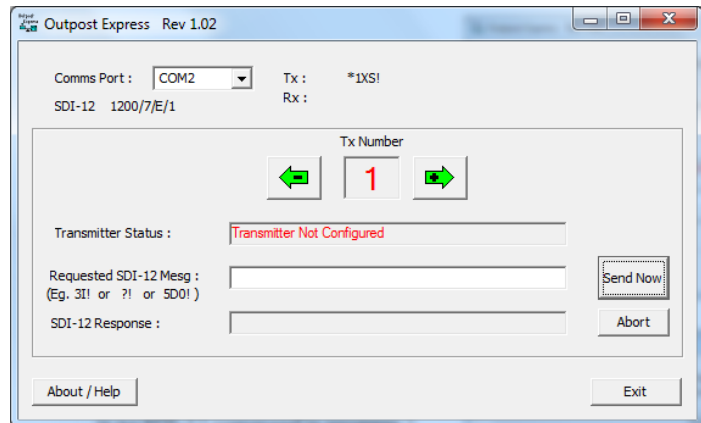

(“No Command Request” means there is no SDI-12 command in progress.)

Type in the SDI-12 command that will be passed to the appropriate Transmitter.

Then click on “Send Now”

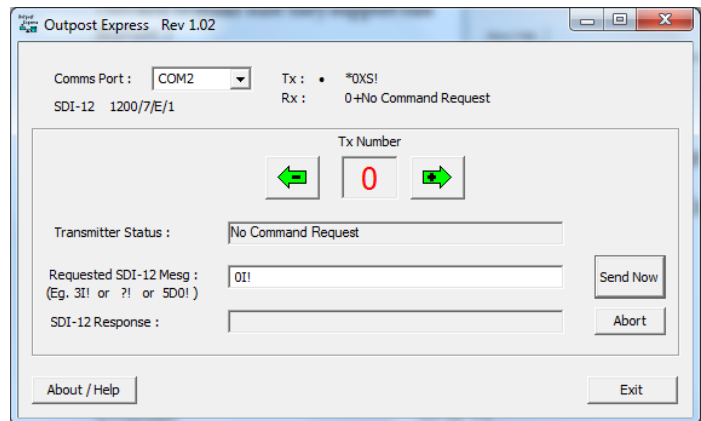

As the transmission sequence occurs, various messages will appear which indicate the request progress.

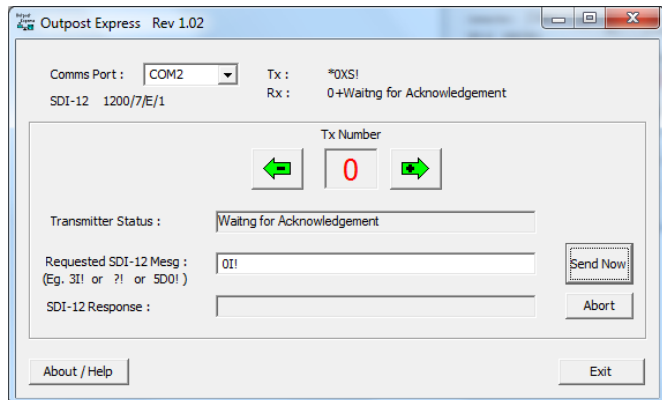
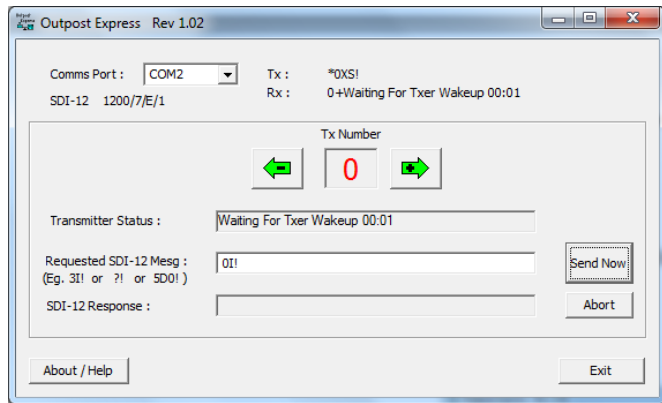

When complete, the SDI-12 response from the command will be passed back through the network and appear as a green highlighted message – as shown.

The “No Command Request” will again appear as the status, as the command is complete.

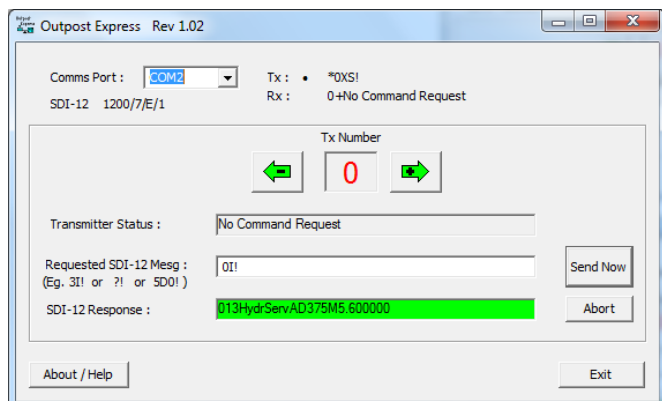

A command may be Aborted at any time.

***** NOTE *****

- Commands will occur faster if the poll time to a Transmitter is set to “0Min”.
- If the poll time is set to any time other than “0Min”, the remote Transmitter will only respond to the SDI-12 command request when it wakes up on the next 1 minute interval. (So the longest time you should have to wait is 1 minute.)
- Once a Transmitter responds to an SDI-12 command using this method, the Transmitter will stay away for a further 1 minute before going back to sleep – so subsequent commands within this time will be actioned quickly.
- Any X command (30char limit) may be sent to the remote SDI-12 device !
- If the SDI-12 command you send is not recognized by the remote SDI-12 device, the response will be “Remote End – SDI-12 sensor didn’t respond”.
- If you send the SDI-12 command ?! and there is more than one SDI-12 device connected to the Transmitter, the response may be garbled.
- You can only send a command to one Transmitter at a time – any previous commands to other Transmitters will be aborted.
- If a command is not actioned in 4 mins it will automatically be aborted.

Method 2 :

If the Data Logger or RTU connected to the Outpost System has an “SDI-12 Transparent” mode, the required custom command may be sent through the Data Logger or RTU.

If the Data Logger or RTU is connected via a modem, then these commands may be sent through a 3G telemetry network – which really opens up the possibilities for this feature.

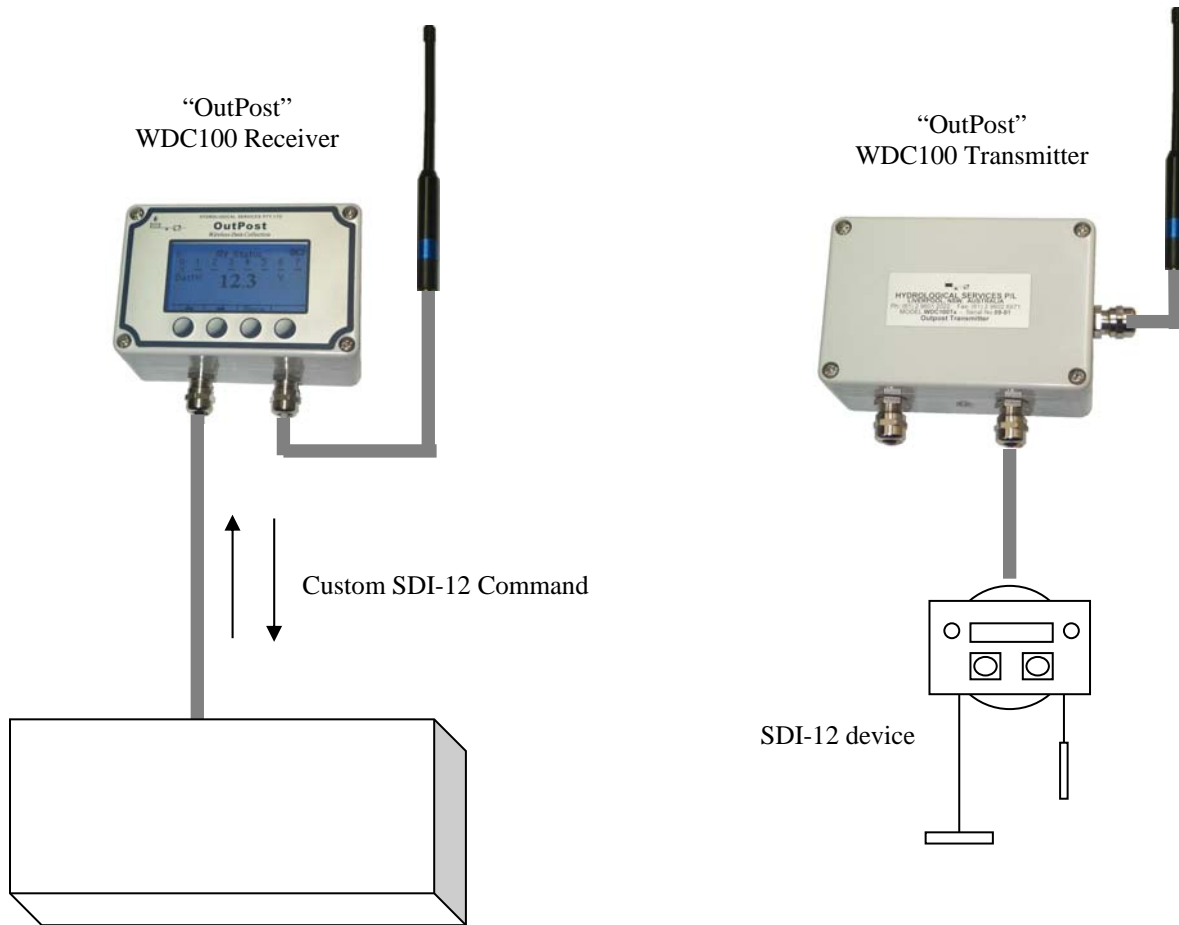

Data Logger or RTU that can send custom commands via an SDI-12 transparent mode.

The SDI-12 X-Command format is as follows :

Request a Custom Command :

As with any SDI-12 command, the first byte is the address of the transmitter, and in the case of the Outpost, this is a number 0 to 7. This SDI-12 command directs a custom command to a particular sensor on a particular Transmitter. (The maximum length message -----! that can be sent is 30 characters (includes the ! mark.)

0XR-----!	(Request that ----- is sent to sensors on Txer #0)
0XR5I!	(Example : Send 5I! to sensors on Txer #0)
0XR?!	(Example : Send ?! to sensors on Txer #0)
0XR5A0!	(Example : Send 5A0! to change sensor address)
2XR0X0+0005.275!	(Example : Send 0X0+0005.275! to sensors on Txer # 2)

The **Response** to this command is the number of characters in the requested message :

0+03<CR><LF>	(This would be the response to 5I! request)
--------------	---

Status of the Custom Command Progress :

The following message requests the status of the custom command sequence from Transmitter #0. (Depending on how frequent the status request is sent, determines which responses are received.)

0XS!	(Status request command)
------	--------------------------

The **Response** to this command will be a “plain English” type message that indicates the progress of the custom command sequence such as :

0+No Command Request<CR><LF>	(No command sequence in progress)
0+No Txer comms yet<CR><LF>	(Transmitter hasn't communicated yet)
0+Txer S/W Rev<1.50<CR><LF>	(Transmitter S/W doesn't have this feature)
0+Waiting For Txer Wakeup 00:04<CR><LF>	(Transmitter not responding yet)
0+Waiting for Acknowledgement<CR><LF>	(Waiting for Txer to ack request)
0+Waiting for SDI<CR><LF>	(Waiting for Txer SDI-12 sequencing)
0+SDI in Progress<CR><LF>	(SDI-12 command in progress)
0+Attempt 1<CR><LF>	(Txer tries 3 times to send the command)
0+SDI-Timeout<CR><LF>	(Sensor did not respond to the command)
0+OK-xxxxxxxxxxxxxxxxxx<CR><LF>	(Response of the SDI-12 command request sequence is xxxxxxxxxxxx) ***This is the response we are waiting for !! The maximum length response is 30 characters.

Abort the Custom Command Sequence :

This SDI-12 command aborts the command sequence with Transmitter address #0

0XA!	(Abort command sequence)
------	--------------------------

The **Response** to this command is the same as the response to the 0XS! Command

***** NOTE *****

- Commands will occur faster if the poll time to a Transmitter is set to “0Min”.
- If the poll time is set to any time other than “0Min”, the remote Transmitter will only respond to the SDI-12 command request when it wakes up on the next 1 minute interval. (So the longest time you should have to wait is 1 minute.)
- Once a Transmitter responds to an SDI-12 command using this method, the Transmitter will stay away for a further 1 minute before going back to sleep – so subsequent commands within this time will be actioned quickly.
- Any X command (30char limit) may be sent to the remote SDI-12 device !
- If the SDI-12 command you send is not recognized by the remote SDI-12 device, the response will be “Remote End – SDI-12 sensor didn’t respond”.
- If you send the SDI-12 command ?! and there is more than one SDI-12 device connected to the Transmitter, the response may be garbled.
- You can only send a command to one Transmitter at a time – any previous commands to other Transmitters will be aborted.
- If a command is not actioned by a Transmitter within 4 mins it will automatically be aborted by the Outpost Receiver.

Example :

In this example we wish to find out what type of sensor is configured as SDI-12 address 5 on Transmitter #0.

A normal command sequence session might look like :

Command Sent	SDI-12 Response
0XR5I!	0+03<CR><LF>
0XS!	0+Waiting For Txer Wakeup 00:02<CR><LF>
0XS!	0+Waiting for SDI<CR><LF>
0XS!	0+SDI in Progress<CR><LF>
0XS!	0+OK+513HydrServAD375M5.6E-123<CR><LF>
0XS!	0+No Command Request<CR><LF>

So the command sent is : 5I!

And the final response returned is : 513HydrServAD375M5.6E-123